

Welding Techniques for Tailored Blanks

Yasunobu MIYAZAKI*¹
Shinji KODAMA*¹

Tatsuya SAKIYAMA*¹

Abstract

Welding principles and notes in laser welding, plasma welding and mash seam welding are discussed. Because of few amount of molten metal in laser welding, it is necessary to keep a gap narrow between welding edges and to track the weld line precisely. High tensile strength steel sheets are easy to weld, in plasma welding, with a lower current than mild steel. And, adding H₂ gas to a shielding gas is effective in improving plasma welding speed. It is necessary, however, to note that too much H₂ gas causes pores in welds. High-speed welding is possible in mash seam welding. Sheet's edges are lapped, then, force and electrical current are applied there with electrode wheels, in this method. Mash seam welding isn't suitable for sheets with too different thicknesses and tensile strengths. And also, cleaning of the electrode surface is necessary in welding of coated steel sheets.

1. Introduction

A tailored blank (TB) or a tailored welded blank (TWB) is a material for press forming obtained by welding two or more steel sheets and tailored to a specific requirement (greater strength, better corrosion resistance, etc.)¹⁻³⁾. By using a TB, it is possible to modify the properties of parts of the blank, improve the yield and reduce the number of parts. With respect to the formability of TBs as well, many commendable studies have been made^{4,5)}. In this paper, consideration is given to laser welding, plasma arc welding and mash seam welding - the welding techniques that are widely employed in Japan to produce TBs - and discussion follows in detail relating to their principles and the matters to be attended to in applying them.

2. Laser Welding

2.1 Principles of laser welding

As shown in Fig. 1, in laser welding, a laser beam is focused on a spot, normally 1 mm or less in diameter, which also shows the focusing property near the focal point when a 6 kW-class Nd-YAG laser beam was condensed. When such an Nd-YAG laser beam (wavelength: 1.06 μm) is irradiated onto a steel sheet, it is absorbed

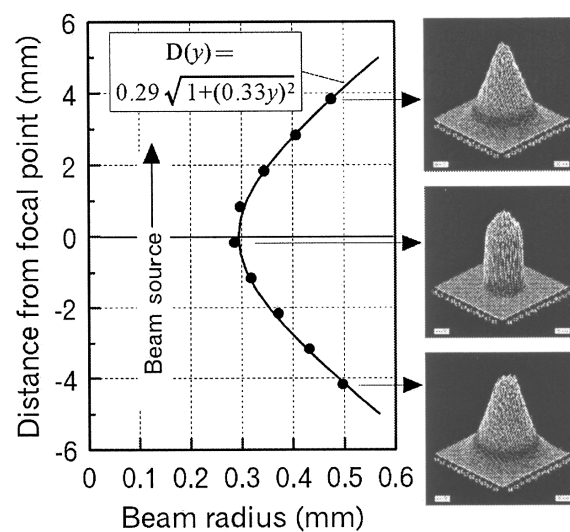

Fig. 1 Focusing of laser beam

*¹ Steel Research Laboratories

at a depth several nanometers from the sheet surface with the absorptance being about 40%⁶⁾. Therefore, the beam serves as a heat source located at the sheet surface, causing its temperature to rise. The input heat is dissipated into the lower-temperature part of the sheet by thermal conduction. Therefore, if the power density of laser is too low, the result is that the region onto which the laser beam is irradiated is only heated superficially.

2.1.1 Heat conduction type welding

As the power density of laser is increased, the steel sheet surface begins to melt and the molten pool begins to spread by heat conduction and heat transport through the flow of molten steel, as shown in Fig. 2(a). Welding under this condition is called heat conduction type welding. Welding by a direct diode laser (DDL) with large Beam Parameter Product, TIG welding, and plasma arc welding of thin sheets are all of the heat conduction type, which generates only small amounts of fumes and produces an optimum weld bead.

2.1.2 Formation of beam hole

When the power density of laser is increased further, the temperature of molten pool surface exceeds 3,000 K, which is the boiling point of iron. As the iron vaporizes, a recoil pressure acts upon the molten pool surface, causing the molten steel surface to curve to such an extent that the pressure balances with the surface tension. As a result, a beam hole as shown in Fig. 2(b) is formed⁶⁾. Documentation⁷⁾ reports the results of measurements of the vapor recoil pressure produced when an SUS 304 sheet was welded using a 3-kW YAG laser. According to such documentation, the speed of the metal vapor was about 250 m/s and the recoil pressure was estimated to be about 6,000 Pa (6% of atmospheric pressure). Since molten steel viscosity is low, the above recoil pressure is sufficient to form a beam hole. For example, at 20 °C, the coefficient of viscosity of water is 1×10^{-2} P and that of glycerin is 15P, whereas the viscosity coefficient of molten steel is as small as 3×10^{-2} at 2,000 °C⁸⁾.

2.1.3 Keyhole welding

When the laser beam is sufficiently powerful, the beam hole penetrates the steel sheet. The beam hole under this condition is specifically called a keyhole, and welding under this condition is called keyhole welding. The laser beam is mainly absorbed by the inner wall of the keyhole that has penetrated through the steel sheet, and transfers the heat to the steel sheet. Compared with heat conduction type welding, keyhole welding is capable of forming an

almost uniform, narrow weld bead across the sheet thickness at a high speed, regardless of the sheet thickness. In butt welding of steel sheets approximately 1 mm in thickness, a weld bead less than 1 mm in width can be formed at a welding speed of 5 m/min. Therefore, keyhole welding causes less deterioration of the material quality and smaller weld distortion than other welding methods. Because of these characteristics, laser welding has become the most suitable welding technique for TB.

The vaporized metal from the keyhole is emitted to the surrounding space in the form of fumes. These fumes are substantial in volume: when a 1.6 mm thick sheet was keyhole-welded, the weight loss of the sheet was about 20 mg/100 mm. The fumes eventually deposit on the sheet and equipment in the neighborhood in the form of metallic particles whose surfaces have been oxidized.

2.2 Special attention in applying laser welding

2.2.1 How to decide welding conditions

By increasing the laser power, it is possible to increase the welding speed and enhance productivity. Therefore, if the welding equipment to be used has been predetermined, it is suggested to weld at the maximum rated output of the laser oscillator, initially. Focus the laser beam on the top surface of the thicker steel sheet and, using welding speed as the only parameter, determine the maximum weldable speed. In this case, attention should be paid to the bead width at the backside surface. It is necessary that the back bead should be uniform in width along the entire length of the weld line and that the bead width should be such that it does not cause incomplete penetration to occur at the back of the sheet even if the butting condition changes. As a general rule, a welding speed can be selected at which the back bead width is 60 to 80% of the surface bead width. If the spattering is too violent, reduce laser power and re-select the welding speed. From the standpoint of reducing spatters, shifting the focal point about 1% of the focal length back from the sheet surface is also effective.

2.2.2 Butting accuracy and weldable range

Fig. 3 shows the range of beam positions that allowed good butt-welding of steel sheets with machined edges using a CO₂ laser. The lower the welding speed and the narrower the gap between butting edges, the wider the range of beam positions for welding. Because of inaccuracies in the sheets set position, linearity of sheet edges and

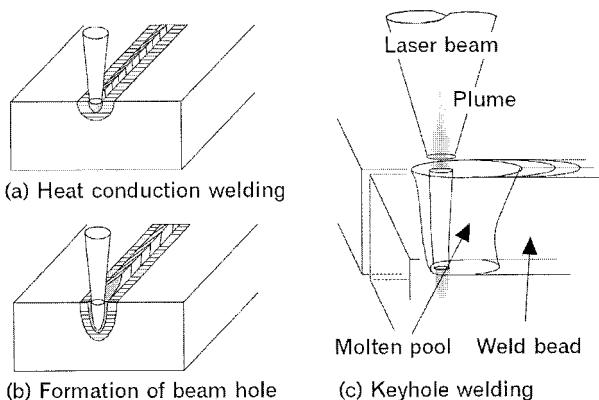

Fig. 2 Relationship between power density of laser beam and mode of welding

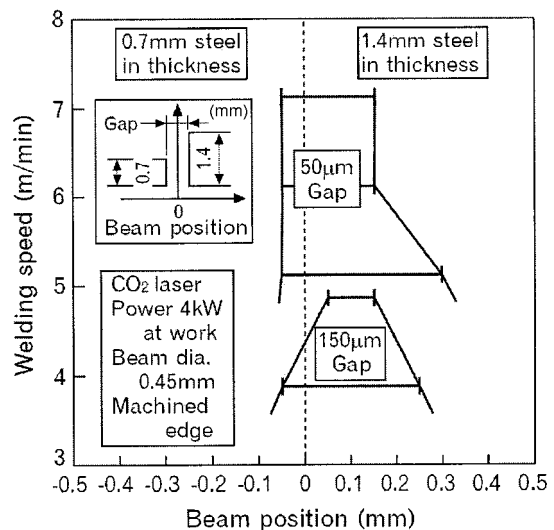

Fig. 3 Effect of gap between butting sheet edges on weldable range

tracking of welding line, it is difficult to keep the aimed beam position in the ideal position. For example, in Fig. 3, if the beam position can be maintained at a position 0.1 mm toward the thicker sheet from the butting position, it is possible to perform butt welding at a speed of 7 m/min or higher assuming the gap to be 50 μ m. However, if the beam is aimed at a position 0.2 mm toward the thicker sheet due to a shift in sheet set position, a defective weld will result when the welding speed is 7 m/min. In the TB production, therefore, it is necessary to select a welding speed with a weldable range in which insufficient linearity of cut edges, inaccurate sheet set positions, etc. can be completely compensated for. In order to increase welding speed, it is necessary to secure the required linearity and improve the accuracy of sheet position setting or weld line tracking.

During welding, the butted faces of the steel sheets tend to be deformed in the direction in which they separate from each other. Therefore, if the sheets are clamped insufficiently, the gap between the butted edges widens during welding. In order to avoid this unwanted phenomenon, it is necessary to sufficiently clamp the sheets by, for example, constraining the part near the weld line.

The weldable range shown in Fig. 3 was obtained by actually performing butt-welding. This work takes more time than generally is expected. By the way, melting a single sheet, rather than butted sheets, by irradiating a beam onto it is called a melt run. Apply a melt run to the thicker sheet and determine the critical penetration speed at which the backside weld bead is formed along the entire length of the sheet. Empirically, in the case of butt-welding, about 60% of the critical penetration speed is the practical welding speed.

2.2.3 Shielding gas

High temperature metal vapor known as a plume jets out of the keyhole (see Fig. 2(c)). This metal vapor interacts with the laser beam, affecting the welding process. How the welding process is affected differs according to the laser wavelength.

With CO₂ lasers that were once the most popular, the laser beam heats the plume itself. This is because the laser beam is absorbed by electrons dispersed in the plume, through inverse bremsstrahlung process⁹⁾. As a result, the plume turns into plasma whose temperature is around 20,000 K. If the plasma becomes excessive, it absorbs the beam to such an extent that welding can no longer be performed. Thus, the role of the shielding gas in CO₂ laser welding is to cool the plasma so as to prevent it from becoming too large. The important requirements of the shielding gas are a large ionization potential and cooling capacity. Accordingly, helium is sometimes used as the shielding gas even though it is comparatively expensive.

In the case of YAG lasers and other solid lasers, which have become widespread in recent years (wavelength: about 1 μ m, close to that of visible light), their beams do not have the capacity to heat the plume. Therefore, the role of the shielding gas in solid laser welding is to prevent the metal vapor from being blown up along the beam axis, thereby preventing the laser beam from being scattered and attenuated by metallic particles and the protective glass from being stained. Since the weld metal is cooled rapidly, it is not oxidized very fast even when the weld zone is not shielded from the open air. Therefore, welding is possible even without a shielding gas.

2.2.4 Imperfection of weld

Typical imperfections of welds are: (a) under-fill, (b) holes, (c) incomplete penetration, (d) incomplete fusion and (e) pore inclusion.

In laser welding, the weld bead is narrow and the amount of fusion is small. Therefore, if there is any gap between the butted faces, the weld bead tends to be subject to an excessively large under-fill and perforated easily. In such a case, it is necessary to increase the amount

of fusion. However, simply increasing the laser power is not enough to significantly increase the amount of fusion. The reason for this is that even when the laser power is increased, it only causes a decline in thermal efficiency because the laser beam reflected by the inner wall of the keyhole passes through the steel sheet. In order to increase the amount of fusion substantially, it is necessary to take other actions, such as increasing the beam diameter at the sheet surface by shifting the focal point from the sheet surface, decreasing the beam that passes through the gap between the butted faces by splitting the beam, and lowering the welding speed.

For the mechanisms by which pores occur in the weld bead, see the documentation 1).

3. Plasma Arc Welding

3.1 Principles of plasma arc welding

Fig. 4 schematically shows the plasma arc welding process (hereinafter referred to as “plasma welding”). Plasma is an arc heat source having a high energy density obtained by converging arc plasma generated from a tungsten electrode by the thermal pinching effect of a water-cooled restraint nozzle. Because of this, plasma welding has characteristics different from those of other arc welding¹⁰⁾. As is evident from Fig. 4, the parameters used in plasma welding are welding speed, welding current, shielding gas flow rate, restraint nozzle diameter and pilot gas flow rate.

Typical welding conditions are shown in Table 1. For a comparatively thick sheet (thickness: about 2.6 mm or more), the pilot gas is passed at a high flow rate from the restraint nozzle to achieve keyhole welding. For a comparatively thin sheet (thickness: about 2 mm or less), by contrast, the flow rate of the pilot gas is lowered to prevent the formation of a keyhole and heat conduction type welding is applied. In the case of a joint for sheets having different thickness, plasma welding is applicable as long as the thickness ratio is within about 3. Although plasma welding is inferior in welding speed to laser welding (the welding speed is about one-third that of laser welding), it is somewhat superior in terms of the permissible gap between butted faces (about 20% of the sheet thickness).

3.2 Special attention in applying plasma welding

3.2.1 How to increase welding speed

Compared with other welding methods applied to TB, plasma welding is inferior in efficiency. Therefore, various efforts to enhance the efficiency, specifically the welding speed, of plasma welding are studied. The factor that governs the welding speed of plasma welding is the occurrence of an irregular bead caused by the application of a

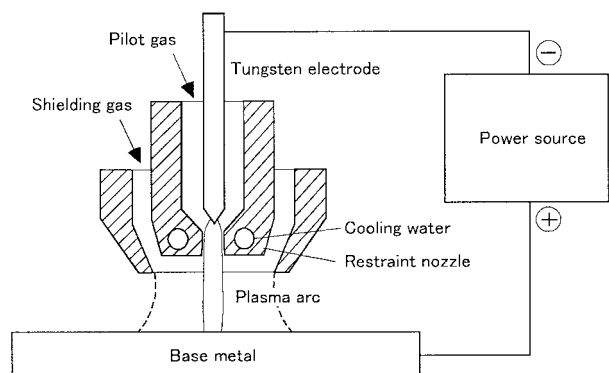

Fig. 4 Schematic illustration of plasma welding

Table 1 Typical welding conditions

Combination of steel plates (thickness)	Welding speed	Welding current	Diameter of restraint nozzle	Flow rate of pilot gas
t = 1mm / 1mm	1.5 m/min	120A	2.8 mm	0.4 L/min
t = 2.6mm / 2.6mm	0.8 m/min	165A	2.4 mm	1.1 L/min
t = 1mm / 2.6mm	0.8 m/min	140A	2.8 mm	0.5 L/min

large welding current as shown in Fig. 5¹¹⁾. Namely, in order to increase the welding speed, it is necessary to increase the welding current so as to secure sufficient penetration. However, as the welding current is increased, the arc pressure rises, causing an undercut or humping bead to occur easily. Therefore, in order to enhance the efficiency of plasma welding, it is necessary to secure complete penetration at a moderate welding current or reduce the arc pressure.

As an example, in high-speed MAG arc welding of thin sheet, multiple electrodes are sometimes used¹²⁾. This is to disperse the arc pressure and thereby restrain the occurrence of an irregular bead. Adding hydrogen or helium to the ordinary shielding gas (Ar) is also an effective means of attaining a high welding efficiency. Both gases increase the amount of fusion by raising the arc voltage and increasing the plasma power intensity. In addition, since hydrogen and helium are light-element gases, they allow for the reduction of arc pressure¹³⁾.

Although this has nothing to do with the shielding gas, a technique to enhance the penetration by applying an oxide-based flux to the sheet surface (A-TIG) has attracted attention in recent years¹⁴⁾. It is expected that this new technique will be put to practical use in the near future.

3.2.2 Influence of chemical composition of steel

On the conditions for heat-conduction type plasma welding applied to thin sheet, the convection of molten metal is an important mechanism for melting the base metal. Therefore, the chemical

composition of steels, which governs the surface tension and viscosity of molten metal, influences the penetration as well. Studies on TIG arc welding have proved that sulfur acts as a surface-active atom. As the amount of sulfur addition is increased, the direction of convection near the surface of molten pool changes from “outward” (i.e., flow toward the periphery of the molten pool) to “inward” (i.e., flow toward the heat source). As a result, the high temperature molten metal is transported in a vertical direction, increasing the penetration depth and allowing a backside bead to be formed even in a comparatively small current region. Carbon - another basic element added to steel - also influences the penetration depth. Fig. 6 shows examples of weld cross sections. It can be seen that a good backside bead was obtained by increasing the amount of added carbon. There is the tendency that increasing the amount of added silicon makes the backside bead flatter and smoother. Generally speaking, at a given welding current, high-strength steel sheet allows for better penetration than mild steel sheet, which contains smaller amounts of alloying elements.

3.2.3 Prevention of pores

In applying plasma welding, it is necessary to pay attention not only to the formation of a weld bead, as mentioned above, but also to the occurrence of pores. In many cases, steel sheets for TB are welded with rust-preventive oil left applied to the sheet surface. Ordinarily, welding steel sheets as delivered will not cause marked pores to occur even when they are not removed of the oil and dried beforehand. However, if a large volume of hydrogen is added to the shielding gas, it is possible that hydrogen dissolved in the molten metal forms pores as its solubility sharply decreases when the molten metal solidifies. Apparently, therefore, it has become common practice to limit the amount of hydrogen added to the shielding gas to 7% or so.

On the other hand, with respect to the influence of the inclusion of air, special attention should be paid to the backside of the weld. Since air can cause oxidation of the backside of the weld zone and formation of an irregular bead, if not pores, it is desirable to provide back shielding. Incidentally, in plasma welding of galvanized sheets, there is the fear that vaporized zinc might disturb the shielded condition. Yet, the authors have never experienced such an undesirable phenomenon. It should be noted, however, that the vaporized zinc does alloy with the restraint nozzle, causing the nozzle diameter to change and even affecting the welding phenomenon. Therefore, in plasma welding of galvanized sheets, periodic maintenance of the restraint nozzle is especially important.

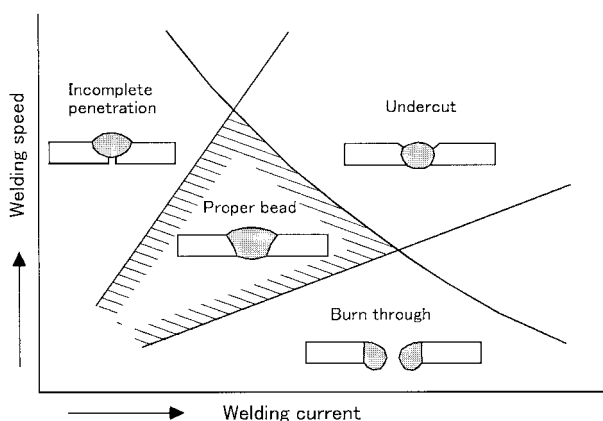

Fig. 5 Effect of welding current and welding speed on bead configuration

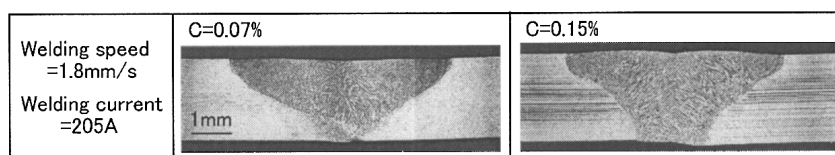

Fig. 6 Effect of carbon content on penetration depth

3.2.4 Other considerations

The plasma welding process does not require costly equipment and is relatively easy to introduce. However, when it comes to applying plasma welding, it is necessary to give due consideration not only to the influences of the shielding gas and the steel's chemical composition as mentioned above, but also to hot cracking of the weld metal. Besides, in plasma welding with a high welding speed and a large welding current, there is the tendency that the permissible gap between the butted sheets is narrower. To make effective use of the wide gap permitted by plasma welding, an excessively high welding speed should be avoided. As has been described so far, there is unique know-how to apply the plasma welding process and hence, a preliminary study of optimum welding conditions is indispensable.

4. Mash Seam Welding

4.1 Principles of mash seam welding

As schematically shown in Fig. 7, the mash seam welding process is one in which the sheet edges to be welded overlap each other and are mashed by the pressure and current applied from rotating wheel electrodes (electrode wheels). The basic conditions for this process are: (1) welding current, (2) applied pressure (overlap width, welding force) and (3) welding speed. The phenomena involved in this particular process are described in detail below.

The authors "froze" the welding process halfway by shutting off the electric current and observed the weld cross-sections before and

after the current shut-off. Fig. 8 shows the observed results. Fig. 8(a) shows a longitudinal cross section of the nugget formed along the weld, and Fig. 8(b) shows transverse cross sections at six positions perpendicular to the weld line. They reveal the welding process from the unwelded zone to the welded zone. When the overlapped parts of the sheets are pinched by the electrode wheels, the resistance heating by electrical current causes the sheet temperature to rise and the sheets to soften. Then, the overlapped parts are mashed by the electrode wheels (the cross sections of positions 1 and 2 in Fig. 8(b)). At this point in time, the temperature at and around the overlapped surfaces (faying surface) is highest and the faying surface is gradually pressure-welded while slanting. Eventually, they are subjected to significant deformation in which the cut ends of the sheets face the electrode wheels (Fig. 8(c)), the welded zone is mashed and the total sheet thickness decreases.

While the melting of sheets begins when the wheel electrodes leave the welding zone (the cross section at position 3), the fusion zone (nugget) is formed in the thickness center almost in parallel with the sheet surface (the cross sections of positions 4 and 5), regardless of the position of the joint interface. The fact that the nugget grows in the thickness center of the weld zone, not at the joint interface, is due to the removal of heat by the electrodes. Thus, in many cases, the weld zone in mash seam welding is formed by a combination of the pressure-weld zone, or the joint interface, and the nugget. Depending on the welding conditions selected, however, the fusion zone may be formed along the entire joint interface¹⁵⁾.

As is evident from the principles of mash seam welding described above, this welding process has these advantages: (1) Although mash seam welding is a kind of lap welding, it is capable of producing a weld zone of nearly the same thickness as that obtained by butt welding (It should be noted, however, that the thickness of the weld zone is not smaller than that of the single sheet. For example, when sheets of the same thickness are welded by this process, the thickness of the weld zone becomes 1.2 to 1.4 times that of the sheet.); (2) Compared with laser welding or other butt welding processes, this process permits high-speed welding relatively easily; and (3) The cutting accuracy required of the sheets to be welded by this process is not as strict as that required by laser welding.

On the other hand, the mash seam welding process has these disadvantages: (1) It is unsuitable for welding curved lines; (2) It is subject to stricter limitations on the thickness ratio than other welding processes; and (3) It results in level differences along the weld zone.

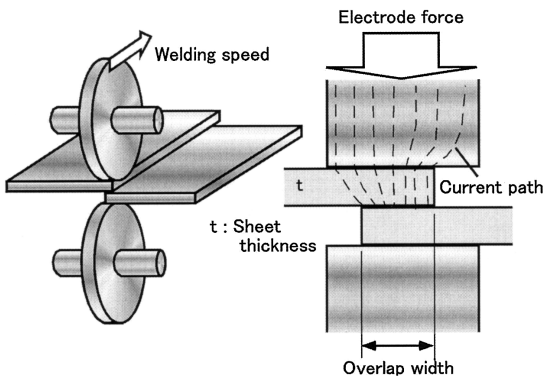

Fig. 7 Schematic illustrationS of mash seam welding

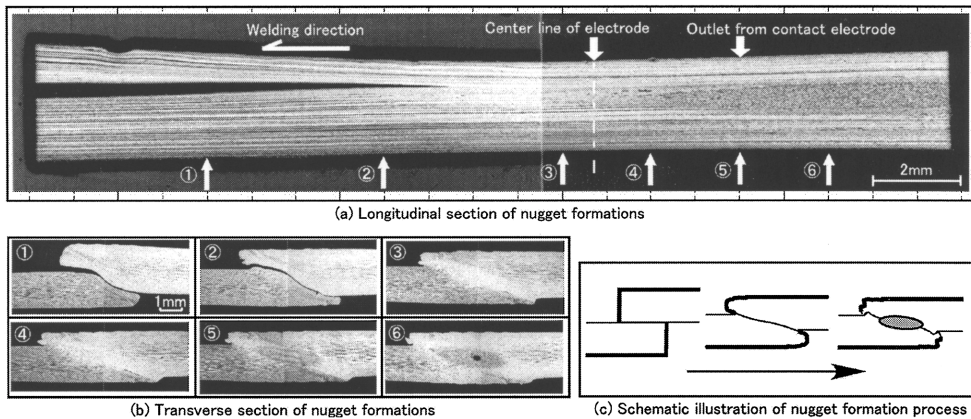

Fig. 8 Nugget formation process through cross-sectional observation

4.2 Special attention in applying mash seam welding

4.2.1 Overlap width

In mash seam welding, the width of the nugget formed has nothing to do with the electrode wheel width. Ordinarily, the width of the nugget formed is considerably smaller than the electrode wheel width. The reason for this, as shown in Fig. 7, is that mash seam welding utilizes the geometric current concentration by partially overlapping the sheets to be welded. The smaller the overlap width, the higher the current concentration. A higher current concentration allows for welding at a higher speed. However, there are reports that the joint strength sharply declined when the overlap width fell below 80% of the sheet thickness¹⁶⁾.

4.2.2 Welding speed

Fig. 9 shows the influence of welding speed on the suitable welding current range in which a sound weld can be obtained. When the welding current is gradually increased with the welding speed kept constant, it becomes possible to obtain a welded joint, which causes the fracture at base metal in a tensile test. The current at which such a welded joint is obtained is called the lower limit current (value). When the welding current is increased further, a phenomenon whereby molten metal spatters from the joint interface begins to occur. The current at which this phenomenon begins to occur is called the upper limit current (value). When the welding speed is increased, the time for which the current is conducted to the sheets decreases, making the heat input insufficient. As a result, the lower limit current shifts toward the higher current side. By contrast, the upper limit current at which the welding can be done without causing expulsion shifts toward the lower current side when the welding speed is increased, since the electrode force is lost before the molten metal solidifies to such a degree that expulsion will not occur. Thus, if the welding speed is raised excessively, the lower limit current increases and the upper limit current decreases, narrowing down the suitable welding current range. Besides, the tolerances for various factors, such as the overlap width, decline, causing the percentage of defects to increase.

4.2.3 Electrode force

When the electrode force is increased, the expulsion restraining effect is enhanced, causing the upper limit current to shift toward the higher current side. On the other hand, the contact resistance that exists between the sheets decreases, causing reduced heat generation. As a result, the lower limit current slightly shifts toward the higher

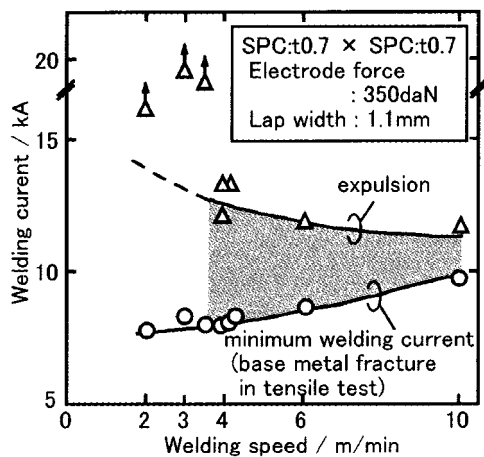

Fig. 9 Effect of welding speed on weldable current range

current side. Thus, increasing the electrode force causes the suitable welding current range to shift toward the higher current side as a whole and become wider.

4.2.4 Welding of sheets having different thickness

As mentioned earlier, the nugget tends to be normally formed in or around the thickness center of the mashed weld zone, regardless of the position of the joint interface. If the sheets to be welded together differ in thickness widely, the faying surface shifts toward the thinner sheet from the thickness center of the weld zone, whereas the nugget is formed in the thickness center. Namely, the nugget is formed away from the faying surface. Because of this, in its technical material, Soudronic AG recommends that the thickness ratio should be 2.5 or smaller¹⁷⁾. However, from the standpoint of securing sufficiently stable weld quality, the authors would recommend 2.0 or less.

4.2.5 Welding of sheets having different strength

When sheets, which differ markedly in strength, are welded together, the stronger sheet is pushed into the less strong sheet, causing the faying surface to shift toward the less strong sheet considerably. As a result, the nugget formed in the thickness center of the weld zone comes away from the faying surface. When it comes to welding sheets of different strength, therefore, it is to be desired that the difference in strength should be as small as possible.

4.2.6 Maintenance of electrodes

When mash seam welding is applied to coated steel sheets, coated metal and an alloy of coated metal and the electrode copper deposit on the electrode wheel surfaces. The formation of a deposit layer causes the contact resistance between the electrode and sheet to increase and hence, flashing from the sheet surface near the electrode tends to occur easily. Thus, when coated steel sheets are welded using this process, the quality of the weld easily tends to become unstable due to contamination of the electrodes. Therefore, maintenance of the electrode surfaces is more important than when the process is applied to bare sheets. Specifically, the electrode surfaces should be ground frequently or periodically with a cutting tool.

4.2.7 Clamping of sheets to be welded

Right after the start of welding, the set lap width remains unchanged. However, as the welding proceeds, the lap width gradually decreases. Ultimately, the lap might be lost completely.

The faying surface between the overlapped sheets inclines due to a deformation of the sheets during welding and forms an angle against the sheet surface. As a result, the welding force applied by the electrodes develops a component, which acts in the direction in which the sheets are forced to separate from each other. In the presence of this force component, the loss of lap occurs for the following reasons.

When the distance between the clamping fixture and electrode wheel is too large, the sheets are subjected to an out-of-plane deformation between the electrode and clamp, resulting in the failure of the lap to be lost.

When the sheets are insufficiently constrained due to insufficient clamping force, etc., the sheets being welded slip under the clamping fixture due to the component of force causing a loss of lap.

Special care should be exercised not to set an excessively small lap, which causes the angle between the faying surface and sheet surface to widen and the component of force causing a loss of lap to increase, making it easier for the above phenomenon to occur.

Measures taken to prevent the loss of lap in the application of this particular welding process include: (1) Avoid setting an excessively small lap width; (2) Make the distance between the clamping fixture and electrode wheel as short as possible; (3) Use a sufficiently rigid clamping fixture and conveyance cart; and (4) Set

the end-of-welding lap width slightly larger than the start-of-welding one to compensate the loss of lap.

4.2.8 Quality control of weld zone

Sometimes, the temperature of weld surface or the voltage between electrodes is monitored with the aim of monitoring the weld quality. There are also cases in which the nugget formation are checked by a microscopic examination of cross-sections of the weld in a sampling inspection. However, observing the nugget formation alone is not enough to accurately judge welding quality. For example, the weld of mild steel sheets shows good formability even without the formation of a nugget, whereas some high strength steel sheets show poor formability even when a nugget is formed. Thus, the presence of a nugget is not an essential requirement in the quality standards for mash seam weld. Rather, criteria for the weld quality are often set for the specific parts to which this welding process is applied or for a specific forming process of welded blanks.

5. Conclusion

This paper describes the principles of laser welding, plasma welding and mash seam welding which are used in the TB production and discussed the matters to be attended to when applying those welding techniques. The authors would be very satisfied if those who are or will be involved in the production of TB find this paper useful in solving any of their welding problems.

References

- 1) Miyazaki, Y. et al.: Nippon Steel Technical Report. (88), 39 (2003)
- 2) Natsumi, F.: Press Technology. 34 (8), 18 (1996)
- 3) Kuroda, A.: Journal of Society of Automotive Engineers of Japan. 59 (11), 63 (2005)
- 4) Hashimoto, K. et al.: The 202nd Symposium on Technology of Plasticity. 2001, p.27
- 5) Uchihara, M. et al.: Quarterly Journal of the Japan Welding Society. 23 (4), 541 (2005)
- 6) Ohji, N.: Basics for Welding and Joining Processes. Sanpo Publications, Inc. 1996
- 7) Mizutani, M. et al.: Preprints of the National Meeting of J.W.S. 67, 2000, p.110
- 8) Rikagaku-ziten. 3rd edition. Iwanami Shoten. 1977
- 9) Ono, M. et al.: Quarterly Journal of the Japan Welding Society. 10 (2), 239 (1992)
- 10) Welding and Joining Handbook. 2nd Ed. Maruzen, 2003, p.251
- 11) The Physics of Welding Process. Kuroki Publishing, 1996, p.140
- 12) Ueyama, T. et al.: High Productivity Welding Processes. Kuroki Publishing, 2003, p.80
- 13) Satoh, T. et al.: Doc. of Welding Arc Physics Committee of Japan Welding Society. 2001
- 14) Tanaka, M. et al.: High Productivity Welding Processes. Kuroki Publishing, 2003, p.11
- 15) Yamauchi, N. et al.: Resistance Welding Research Committee of Japan Welding Society. RW-187-80, 1980
- 16) Funk, E.J. et al.: Welding J. 35 (6), 265 (1956)
- 17) Soudronic Neftenbach AG: Souma-Welding